

Hybrid Excited Synchronous Machine with Flux Control Possibility

Paolo Di Barba^a, Maria Evelina Mognaschi^a,
Michal Bonislowski^b, Ryszard Palka^{b,**}, Piotr Paplicki^b, Rafal Piotuch^b, Marcin Wardach^b

^a *Department of Electrical, Computer and Biomedical Engineering, University of Pavia,
via Ferrata 5, 27100 Pavia, Italy*

^b *Department of Power Systems and Electrical Drives, West Pomeranian University of Technology,
Sikorskiego 37, 70-313 Szczecin, Poland*

Abstract. The paper presents simulation and experimental results of an Electric Controlled Permanent Magnet Synchronous (ECPMS) machine that offers an extended magnetic field control capability which makes it suitable for battery electric vehicle drives. Rotor, stator and additional direct current supplied coil of the machine have been analyzed in detail. Control and power supply systems of the machine have been presented. Influence of the additional excitation on the machine performance has also been discussed.

Keywords: electric vehicles, permanent magnet machines, hybrid excitation, field-weakening, flux control

1. Introduction

The advantage of machines with high flux density values in the low speed range used for electric vehicle drives is inherently connected with challenges in the high speed operation regions, where due to the limited battery voltage values a strong field weakening possibility is required. This paper presents a machine topology that enables field weakening with an additional stator fixed DC-coil, offering wide speed variations.

2. Design and Optimization of the ECPMS Machine

Fig. 1 shows a 3-phase design of ECPMS-machine with a 12-pole double inner rotor topology. Armature windings are located in 36 slots on both sides of two stator stacks. On one side of the machine the rotor is formed by the exhibited PMs of single polarity, along with iron poles made from a soft magnetic composite (SMC) material. On the other side of the machine the same arrangement is applied with PMs of inverse polarity. The flux generated by PMs passes through laminated stator cores pole pieces, and it crosses the air-gap of the machine in the radial direction. Main portion of the flux passes through the SMC stator core in the axial direction, and it returns via the rotor core. The remaining part of the flux excited by PMs returns to the iron poles of the rotor. The flux passing through the iron poles is very important from the point of view of the field-weakening capability 0, [2].

In order to realize a field excitation control (increasing or decreasing the magnetization level of the machine) an auxiliary DC-coil is mounted centrally inside the stator core, between two laminated stators. This allows to vary the effective excitation field and voltages induced in the armature windings.

**Corresponding author: Ryszard Palka, WPUT, Sikorskiego 37, 70-313 Szczecin, Poland. E-mail: rpalka@zut.edu.pl

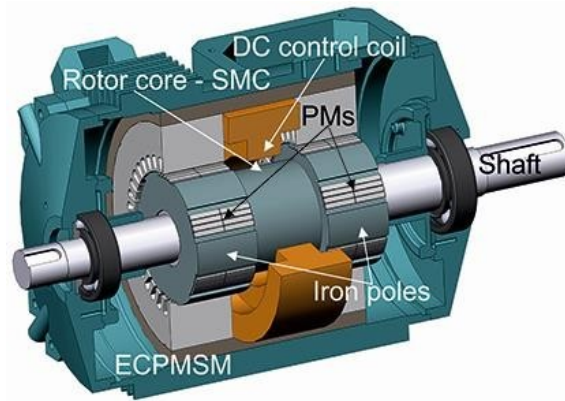

Fig. 1. Cross section of the ECPMS-machine.

It is of great interest to improve motor geometry by design optimization, thus to reduce production costs and improve the performance of a drive system. The fundamentals of the field optimization have originally been described in [3], [4], e.g. Optimization of the machine topology has been performed in many steps, for the stator and the rotor separately or for both together. This task can be divided into many connected to each other subtasks: optimization of the rotor structure, optimization of the rotor shape, optimization of the PM shape and magnetization, optimization of the stator structure, optimization of the stator shape, optimization of windings, optimization of the additional supply coil. Such optimization problem is a typical Multiobjective Optimization Problem (MOP) subject to a set of constraints. Usual objective functions for such optimization are: mass minimization, torque maximization, minimization of the cogging-torque ripples, proper inductances values, proper back emf, etc., and typical constraints are following: non-saturation of the magnetic core, defined maximum current density in the windings, maximum power losses, maximum local temperature (windings, PMs), maximum geometrical dimensions, limited amount of magnetic material, manufacturability, maximum costs, etc.

After solving the MOP a set of optimal non-dominated solutions is generated creating a Pareto front giving a set of models for selection of best solution. The final selection can be made taking into account other features that the motor should have. Details of this methodology have been described in [8] e.g. The initial 2D optimization of the machine has partially been done in [2]. The main geometrical dimensions of the machine under study were defined by the application requirements and the design problem consisting of identifying some crucial dimensions of the machine was formulated. In [2] the NSGA-II algorithm was applied for solving the multi-objective problem of minimizing the mass of the motor while maximizing the average torque value. The optimization was based on 2D-FEA calculations; only a posteriori, in the post-processing step, the optimization results were assessed by means of 3D-FEA simulations. The impact of the control coil on the optimal design was taken into account only in the post-processing phase. The minimization of the cogging torque in the ECPMS motor using the topological gradient and a modified multi-level set method with total variation regularization has been performed in [5] and [6], respectively. The topology optimization of rotor poles in the ECPMSM using level set method and continuum design sensitivity analysis has been presented in [7]. Finally, for the optimization of the machine, two different optimization algorithms have been developed and adopted: Genetic Algorithm (GA) and Sequential Surrogate Optimizer (SSO) [8]. In this way it was possible to determine all geometrical dimensions of the machine and fulfill all fundamental optimization targets (fully or partially).

Following figures demonstrate some optimization stages of different parts of the ECPMS-machine. Fig. 2 shows a cross section of the ECPMS-machine with some crucial design variables and the final 3-D field distribution within the machine. The evolution of the rotor geometry has been shown in Fig. 3. The final version of the prototype rotor (formed by modified soft magnetic composites technology) is given in Fig. 3 (right).

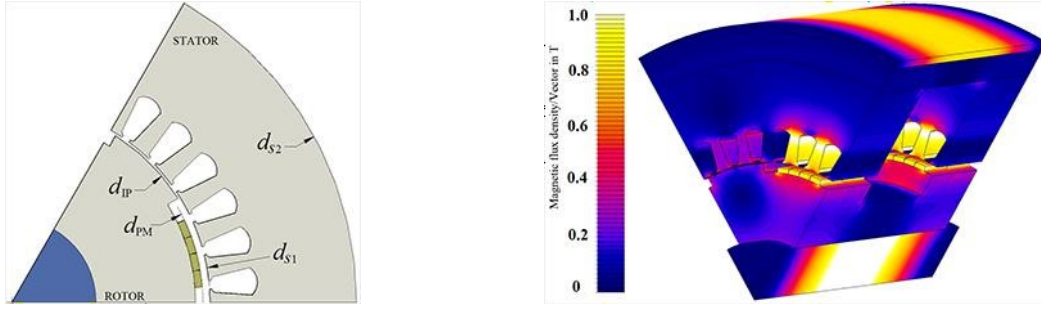

Fig. 2. Cross section of the ECPMS-machine (left). Magnetic field distribution within 3-D model of the machine (right).

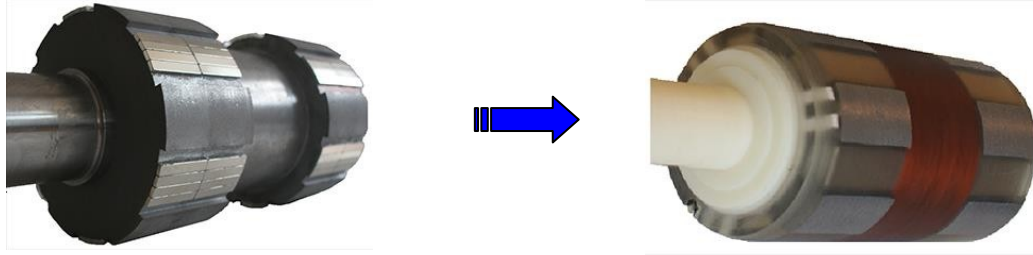

Fig. 3. Evolution of the rotor of the ECPMS-machine. Initial prototype (left); final design (right).

The main goal of the paper is to optimize the flux management in the machine in order to obtain the required field weakening in a wide range of velocities subject to a prescribed torque [9], [10].

3. Design and Optimization of the Supply System

A control strategy (in a steady state and in transient modes) and a new approach to control the power supply system of the machine in the field weakening/strengthening range, or in a fault mode of operation, involves defining an adequate mathematical model of the machine. Following assumptions have been made: symmetric armature windings, constant resistance and inductance of windings, constant flux of magnets, higher harmonics of magnetic flux density are neglected. Typical hybrid machine's voltages and torque equations can be written in the following form ([12], [13]):

$$u_{DC} = R_{DC} i_{DC} + L_{DC} \frac{di_{DC}}{dt} - M_{DC} \frac{di_d}{dt} \quad (1)$$

$$u_d = R_s i_s + L_d \frac{di_d}{dt} + M_{DC} \frac{di_{DC}}{dt} - \omega_e L_{dq} i_q, \quad u_q = R_s i_s + L_q \frac{di_q}{dt} + \omega_e (L_{dd} + L_{PM} + M_{DC}) i_d \quad (2)$$

$$T_e = \frac{3}{2} p (i_q \Psi_d - i_d \Psi_q) = \frac{3}{2} p \left[T_{synch} + M_{DC} i_{DC} i_q + (L_d - L_q) i_d i_q \right] \quad (3)$$

where: e_d, e_q - induced voltages in direct and quadrature axis; T_{synch} - synchronous torque proportional to the i_q (q -axis currents), Ψ_{PM} flux linkage of magnets; T_{DC} auxiliary controlled torque proportional to value and direction of DC current (i_{DC}); T_{rel} - reluctance torque, L_{DC} - self-inductance of the additional coil, M_{DC} - mutual inductance, p - number of pole pairs. The electromagnetic torque equation consists of three significant components:

- synchronous torque T_{synch} - proportional to the current in the q -axis and to the (constant) flux of permanent magnets,
- torque T_{DC} - proportional to the current i_{exc} in additional excitation coil,
- reluctance torque T_{rel} - as a result from the asymmetry of the machine's magnetic circuit.

It must be emphasized, that most of ECPMSM models described in literature, as well as the presented experimental model, shows resultant flux from PM and additional coil as a nonlinear dependency. Graphical representation of the linkages and feedbacks are shown in Fig. 4. Highlighted block of the schema is a part of controllable excitation circuit that is typical for hybrid machines.

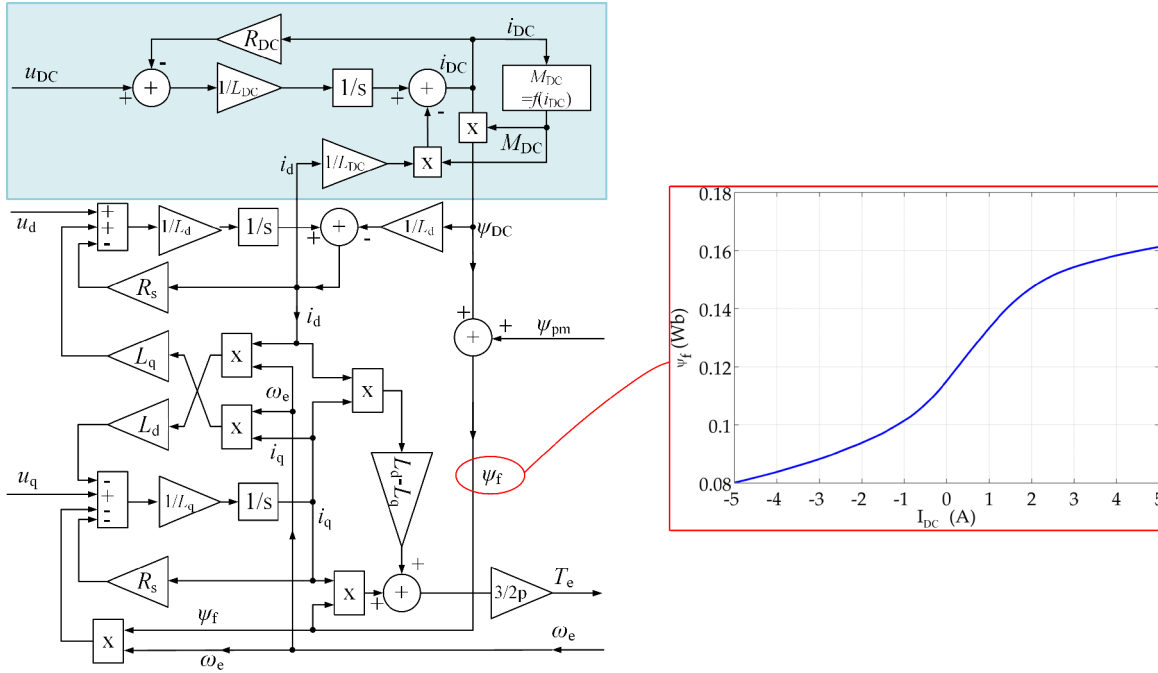

Fig. 4. Block diagram of a synchronous hybrid machine.

Equations (1-3) give the possibility of forming a specified electromagnetic torque at different values of the individual components of the stator current (i_d , i_q) and additional coil current i_{DC} according to the specified control strategy. One of the most common control strategy is: “ $i_d=0$ ” – which does not contribute reluctance torque and any losses. The next strategy is MTPA (Maximum Torque Per Ampere) – which uses reluctance torque in order to increase resultant torque value T_e according to (3) but does not consider losses. The authors propose Maximum Efficiency strategy which results in increased torque value, higher efficiency and broader constant power speed range.

4. Optimization of Control Strategy (Maximum Efficiency)

Significant part of power losses, especially at high rotational speeds, may be produced in the machine magnetic core [8]. Total losses in magnetic material have been modeled as an additional R_c resistor in extended equivalent circuit of the hybrid machine (Fig. 5). R_c value depends on rotational speed of the machine shaft. A model of core losses has been determined using experimental results.

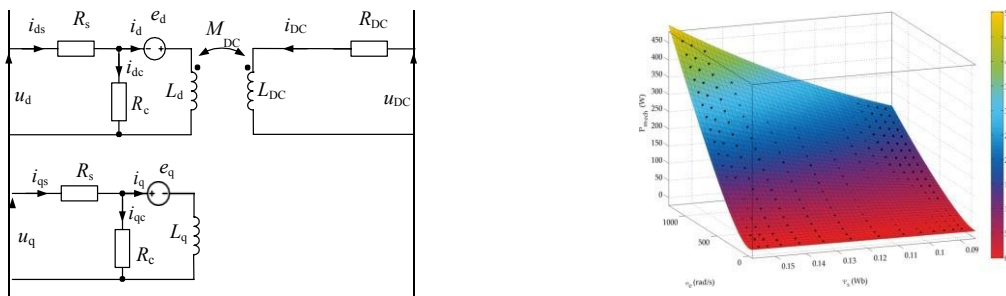

Fig. 5. Equivalent circuit of hybrid machine considering power losses in magnetic core (left). A result of match of mechanical and magnetic losses with measurement points (right).

Because of difficulties with analytical description of a nonlinear model and mutually linked phenomena that occur in the hybrid machine, there has been proposed an idea of initial (off-line), iterative searching for optimal (in sense of selected criteria) parameters of power supply in steady state. Obtained results consist of stator and additional coil current components, applied for selected rotational speed and reference torque values. Proposed method is based on calculation of individual power supply parameters for all defined work points of a drive system. Input variables for individual calculation steps are defined in advance I_d and I_{DC} ranges. Obtained values of required stator current components I_d , I_q and additional coil current I_{DC} are written into Look Up Table (LUT). Next the values are placed in non-volatile memory of microcontroller that realizes a classical Field Oriented Control algorithm (Fig. 6). A positive feature of such solution is a small required calculation speed of a microcontroller (approximate to classic solutions of vector control algorithms). Calculated optimal current values have been shown in Fig. 7.

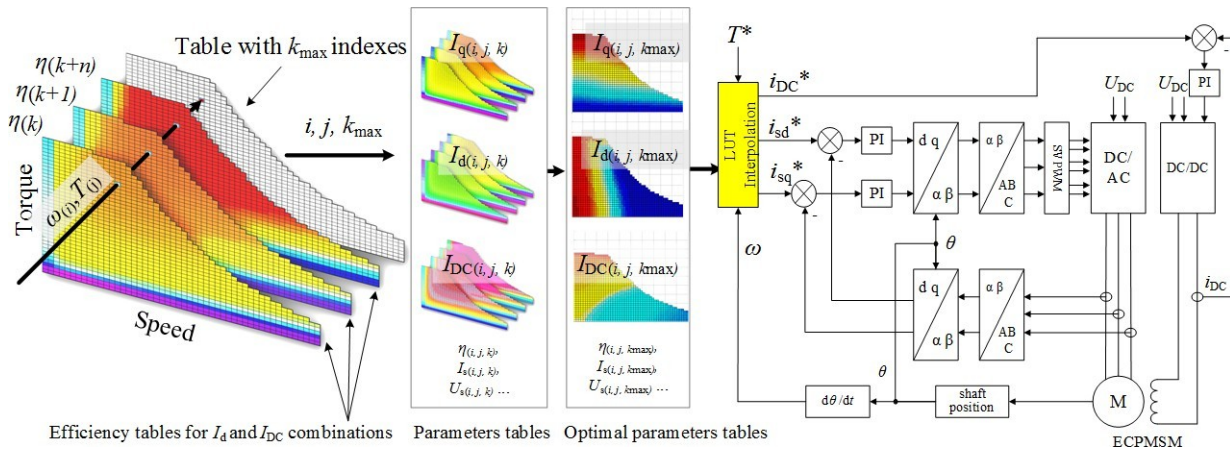

Fig. 6. Selection of coordinates for maximum efficiency value of a drive system with control scheme.

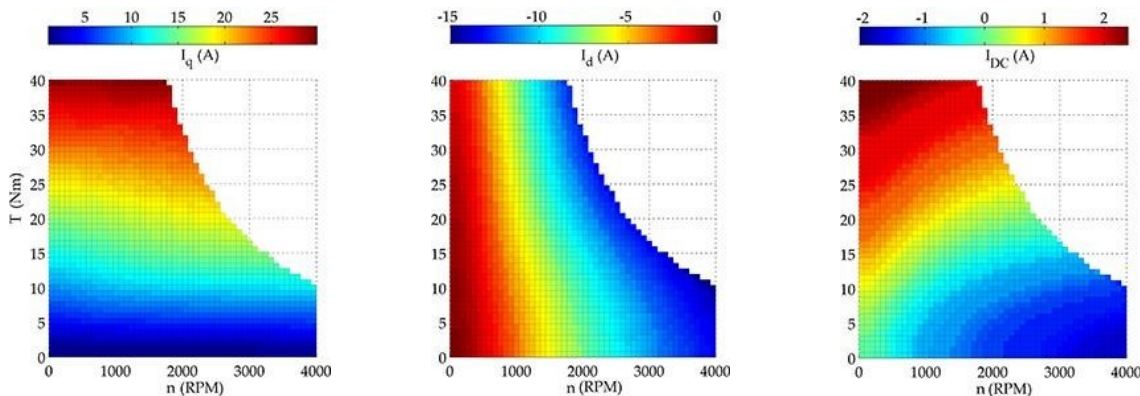

Fig. 7. Calculated optimal current values.

Pursuant to former analysis I_{DC} value increased at low speeds, made it possible to achieve higher torque for a given stator current value. At high speeds, I_d field-weakening effect is boosted with I_{DC} negative current. Consideration of core losses causes direct axis current component to be applied at much lower speed values. Assessment of machines efficiency for proposed control strategy has been performed for experimental results assembled and presented in a form of efficiency maps. The prototype machine at the test stand is shown in Fig. 8. Theoretical efficiency maps obtained during iterative calculations of formulated models and experimental measurement results of the real machine have been shown in Fig. 9. Comparison of theoretical and experimental results gives great accordance between the model and the real object and validates theoretical assumptions drawn at elaboration of each power losses component model. Differences between obtained results are not greater than 1%.

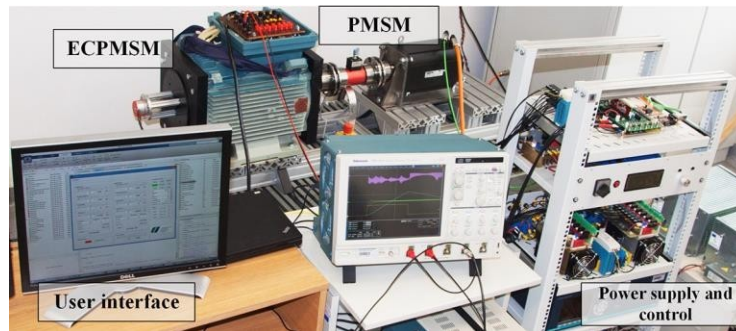

Fig. 8. Test stand and power supply unit.



Fig. 9. Machine efficiency maps: simulation (left), experiment (right).

5. Conclusions

The paper describes a new approach of the magnetic field management in the hybrid excited machine which enables the required field weakening in a wide range of velocities. This modified FOC method together with the Maximum Efficiency strategy can be used in all-electric vehicle drives. It results in increased efficiency, increased nominal torque value and higher constant speed range.

References

- [1] H. May, R. Palka, P. Paplicki, S. Szkolny, W-R Candors, Modified concept of permanent magnet excited synchronous machines with improved high-speed features, *Archives of Electrical Engineering*, **60(4)**, Dec. 2011, 531-540.
- [2] P. Di Barba, M.E. Mognaschi, R. Palka, P. Paplicki, S. Szkolny, Design optimization of a permanent-magnet excited synchronous machine for electrical automobiles, *International Journal of Applied Electromagnetics and Mechanics*, **39**, No. 1-4/2012, 889-895.
- [3] R. Palka, Synthesis of magnetic fields by optimization of the shape of areas and source distributions, *Electrical Engineering* **75** (1991), 1-7.
- [4] R. Sikora, R. Palka, Synthesis of One- and Twodimensional Electrostatic Field, *Electrical Engineering* **64** (1981) 105-108.
- [5] P. Putek, M. Slodička, P. Paplicki and R. Palka, Minimization of cogging torque in permanent magnet machines using the topological gradient and adjoint sensitivity in multi-objective design, *International Journal of Applied Electromagnetics and Mechanics*, **39** No.1-4, Apr. 2012, 933-940.
- [6] P. Putek, P. Paplicki, R. Palka, Low cogging torque design of permanent-magnet machine using modified multi-level set method with total variation regularization, *IEEE Trans. Magn.*, **50**, No. 2, Feb. 2014.
- [7] P. Putek, P. Paplicki, R. Palka, Topology optimization of rotor poles in a permanent-magnet machine using level set method and continuum design sensitivity analysis, *Compel*, **33**, No. 3, 2014, 711-728.
- [8] P. Di Barba, M. Bonislawski, R. Palka, P. Paplicki, and M. Wardach, Design of Hybrid Excited Synchronous Machine for Electrical Vehicles, *IEEE Trans. Magn.*, **51**, No. 8, Aug. 2015.
- [9] K. Ki-Chan, A Novel Magnetic Flux Weakening Method of Permanent Magnet Synchronous Motor for Electric Vehicles, *IEEE Trans. Magn.*, **48**, No. 11, 2012, 4042-4045.
- [10] J.A. Tapia, F. Leonardi, T.A. Lipo, Consequent-Pole Permanent-Magnet Machine with Extended Field-Weakening Capability, *IEEE Transactions on Industry Applications*, **39**, 2003, 1704-1709.
- [11] P. Paplicki, Optimization of the electrically controlled permanent magnet excited synchronous machine to improve flux control range, *Elektronika ir electrotechnika*, **20**, No. 10, 2014, 17-22.
- [12] R. Mbayed, L. Vido, G. Salloum, E. Monmasson, and M. Gabsi, Effect of iron losses on the model and control of a hybrid excitation synchronous generator, IEEE International Electric Machines & Drives Conference, 2011, 971-976.
- [13] N. Patin, L. Vido, E. Monmasson, and J. -P. Louis, Control of a DC generator based on a Hybrid Excitation Synchronous Machine connected to a PWM rectifier, IEEE International Symposium on Industrial Electronics, 2006, **3**, 2229-2234.